

Pressure Reducing Valve - Model S1

BASIC INFORMATION

Type	Self-operated pressure reducing valve with bellows	Kv	3,5 – 450 [m ³ /h]·[bar]
Operation	Valve closes when outlet pressure increases	Cv	4.0 – 520 [gpm]·[psi]
Model	S1	Temperature	-40 to 250 [°C]
Connections	Flanged (DIN - ANSI) or Threaded (BSP - NPT)		-40 to 482 [°F]
Ends	RF – RF, NPT, BSP	Inlet max. pressure	40 [barg] up to DN50 (2")
Ratings	PN25 - PN40 (150# - 300#)	Outlet pressure	25 [barg] up to DN200 (8")
Sizes	DN15 to DN200 [mm] (1/2" to 8")		
Suitable for	Liquids, compressed air, neutral gases and steam		

PARTS

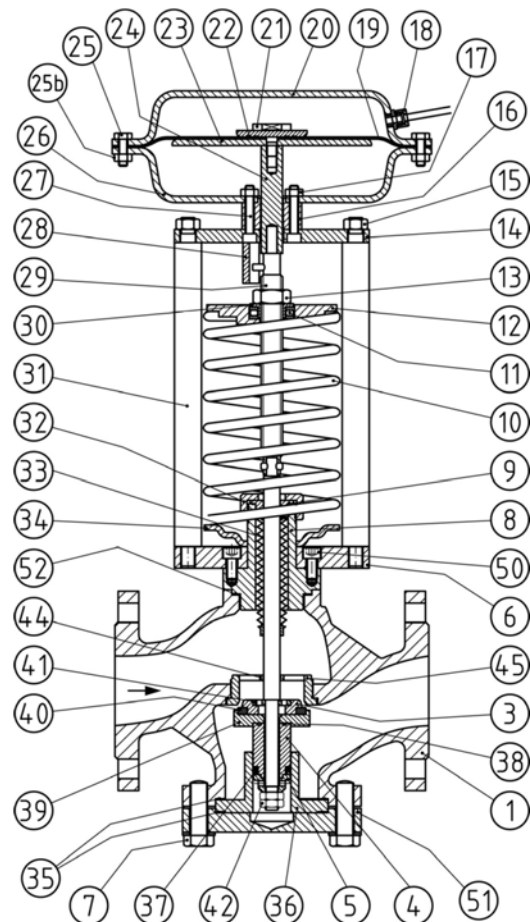

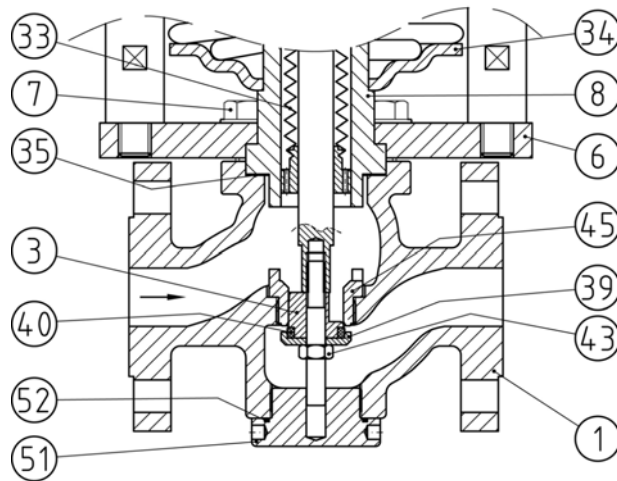

MATERIALS

REF.	PART	MATERIAL	
		ANSI / ASTM	DIN / EN
1	Body	Ductile iron (A536) Bronze (RG10) C. S. (A216WCB) S.S. (AISI 316)	Ductile iron (GGG40.3) Bronze (1705) C. S. (1.0619) S. S. (1.4408)
3	Lower support seal	S.S. (AISI 304L) S. S. (AISI 316L)	S. S.(1.4307) S. S. (1.4404)
4	Guide stem	S.S. (AISI 304L) S. S. (AISI 316L)	S. S.(1.4307) S. S. (1.4404)
5	Washer guide stem	S.S. (AISI 304L) S. S. (AISI 316L)	S. S.(1.4307) S. S. (1.4404)
6	Cover	C.S. (AISI 1045) S.S. (AISI 304L) S.S. (AISI 316L)	C.S. (1.1191) S. S.(1.4307) S. S. (1.4404)
7	Screw	C.S. (F568M class 8.8) S. S. (AISI 304) S. S. (AISI 316)	C.S. (ISO 898-1 class 8.8) S.S (1.4301) S.S. (1.4401)
8	Bellow guide	S.S. (AISI 304) C.S. (AISI 1024) S.S. (AISI 316L) S.S. (AISI 304L)	S.S. (1.1191) C.S (1.0570) S.S. (1.4404) S.S. (14307)
9	O-ring	FKM (D 1418)	FPM (1629)
10	Springs	C.S. (SAE 9255)	C.S.(55Si7)
11	Ball bearing	C.S. (6440K)	C.S. (10Cr6)
12	Upper support springs	C.S. (AISI 1045)	C.S. (1.1191)
13	Adjusting nut	C.S. (F568M class 8.8)	C.S. (ISO 898-1 class 8.8)
14	Support plate	C.S. (AISI 304)	C.S. (1.1191)
15	Nut M12	C.S. (F568M class 8.8)	C.S. (ISO 898-1 class 8.8)
16	Support screws M8	C.S. (F568M class 8.8)	C.S. (ISO 898-1 class 8.8)
17	Nut M8	C.S. (F568M class 8.8)	C.S. (ISO 898-1 class 8.8)
18	Coupling	Brass	Brass
19	Diaphragm	EPDM ((D-1418) [-40°C +125°C]) EPDM + PTFE ((D-1418 + D-792) [+125°C+250°C])	EPDM ((1629) [-40°C +125°C]) EPDM+ PTFE ((1620 + 53749) [+125°C+250°C])
20	Actuator casing (upper)	C.S. ((A1011) painted in epoxy) S.S (ASI 316)	C.S. ((1.0335) painted in epoxy)) S.S. (1.4401)
21	Diaphragm screw	S.S. (AISI 304)	S.S. (1.4301)
22	O-ring	FKM (D 1418)	FPM (1629)
23	Diaphragm plate	C.S. (AISI 1045)	C.S. (1.1191)

24	Diaphragm stem	C.S. (AISI 1045)	C.S. (1.1191)
25	Hexagonal screw M8	S. S. (AISI 304)	S.S. (1.4301)
25b	Hexagonal Nut M8	S. S. (AISI 304)	S.S. (1.4301)
26	Actuator casing	C.S. ((A1011) painted in epoxy) S.S (ASI 316)	C.S. ((1.0335) painted in epoxy) S.S. (1.4401)
27	Allen screw	C.S. (F568M class 8.8)	C.S. (ISO 898-1 class 8.8)
28	Anti-rotation system	C.S. (AISI 1045)	C.S. (1.1191)
29	Regulation stem	S. S. (AISI 304)	S.S (1.4301)
30	Guide ball bearing	S.S. (AISI 304L)	S.S. (14307)
31	Column	C.S. (AISI 1045)	C.S. (1.1191)
32	Nut bellow	C.S. (AISI 1045) S.S. (AISI 316L)	C.S. (1.1191) S.S. (1.4404)
33	Bellow	S.S. (AISI 316L)	S.S. (1.4404)
34	Lower support springs	C.S. (AISI 1045)	C.S. (1.1191)
35	Gasket	Graphite with metal	Graphite with metal
36	Guide	S.S. (AISI 304L) S.S. (AISI 316L)	S.S. (14307) S.S. (1.4404)
37	Gasket	PTFE (D-792) NBR (D-1418) PEEK (D-792) EPDM (D-1418)	PTFE (53749) NBR (1629) PEEK (53479) EPDM (1629)
38	O-ring	FKM (D 1418)	FPM (1629)
39	Upper support seal	S.S. (AISI 304L) S.S. (AISI 316L)	S.S. (1.4307) S. S. (1.4404)
40	Seal	Graphite PFTE	Graphite PFTE
41	Guide stem	S.S. (AISI 304L) S.S. (AISI 316L)	S.S. (14307) S.S. (1.4404)
42	Nut	S.S. (AISI 304L) S.S. (AISI 316L)	S.S. (14307) S.S. (1.4404)
43	Stem seal	S.S. (AISI 304L) S.S. (AISI 316L)	S.S. (14307) S.S. (1.4404)
44	Guide stem	S.S. (AISI 304L) S.S. (AISI 316L)	S.S. (14307) S.S. (1.4404)
45	Seat	S.S. (AISI 304L) S.S. (AISI 316L)	S.S. (14307) S.S. (1.4404)
50	Allen screw	C.S. (F568M class 8.8) S. S. (AISI 304)	C.S. (ISO 898-1 class 8.8) S.S (1.4301)
51	Cover	S. S. (AISI 304)	S.S (1.4301)
52	O-ring	PTFE (D-792)	PTFE (53749)

STANDARD CONFIGURATIONS

DN [mm]	15	20	25	32	40	50	65	80	100	125	150	200
Kv [m ³ /h]-[bar]	3,5	5	9	13,5	22	32	57	82	115	190	240	450

NPS [inch]	1/2"	3/4"	1"	1 1/4"	1 1/2"	2"	2 1/2"	3"	4"	5"	6"	8"
Cv [gpm]-[psi]	4	6	10	16	25	37	66	95	133	220	277	520

A [mm] EN	130	150	160	180	200	230	290	310	350	400	450	600
A [mm] ANSI 150	o	o	184	-	222	254	276	298.5	352.5	-	451	
A [mm] ANSI 300	o	o	197	-	235	267	292	317.5	368	-	-	
L [mm]	440	445	450	455	463	475	560	560	575	600	640	800
Weight [Kg]	20	22	24	28	32	35	52	57	68	85	105	210

o available on request

IMPORTANT NOTE: Kv or CV reduced is available

ACTUATOR DIAMETER ACCORDING TO REQUIRED OUTLET PRESSURE: D [mm]

Outlet Range [barg]	DN15 DN20	DN25 DN32	DN40 DN50	DN65	DN80	DN100	DN125	DN150	DN200
0,1 – 1,5	295	295	295	295	350	350	-	-	-
1 – 3	255	255	255	295	295	295	350	350	350
2 – 5	230	230	230	255	255	255	295	295	295
4 – 8	195	195	195	230	230	230	255	255	255
7 – 16	175	175	175	195	195	195	230	230	230

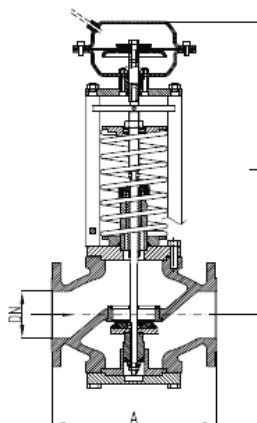
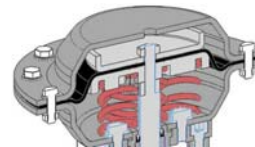

CAGE ANTI CAVITATION (OPTIONAL)



MAIN DESIGN STANDARDS

STANDARD	DESCRIPTION
EN 558-1	Face-to-face dimensions flanges drilled acc. to EN 1092-1
EN 1092-1, 2	Flanges and their joints
ISA 75.03	Face-to-face dimensions flanges drilled acc. to ASME B16.5 or EN 558-2
ASME B16.5	Flanges and Flanged Ratings for Class 150, 300, etc.
EN 10226-1	Requirements for BSP thread
ANSI/ASME B1.20.1	National Pipe Thread Taper
EN 12516-1	Shell design strength - Tabulation method for steel valve shells
EN 60534-2-3	Industrial control valves - Flow capacity - Test procedure
EN 12266-1	Pressure tests, test procedures and acceptance criteria

OPERATION

The medium flows through the valve body in the direction indicated by the arrow. The position of the valve plug determines the flow rate across the area released between the plug and seat.

To control the pressure, the operating diaphragm is pretensioned by the positioning springs and the set point adjuster. As a result, the valve is opened by the force of the positioning springs in pressureless state ($p_1 = p_2$).

The downstream pressure p_2 to be controlled is tapped downstream of the valve and transmitted through the control line to the operating diaphragm where it is converted into a positioning force.

This force is used to move the valve plug depending on the force of the positioning springs. The spring force can be adjusted on the set point adjuster.

When the force resulting from the downstream pressure p_2 exceeds the adjusted pressure set point, the valve is closed proportionally to the change in pressure.

The fully balanced valve is equipped with a balancing bellows, the downstream pressure p_2 acts on the inside of the bellows and the upstream pressure p_1 acts on the outside of the bellows. As a result, the forces produced by the upstream and downstream pressures acting on the valve plug are balanced.

STANDARD INSTALLATIONS

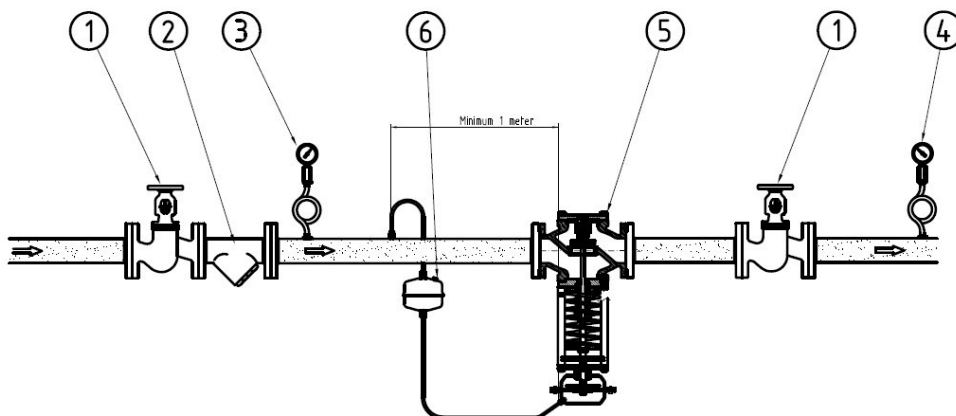

- | | |
|----|-----------------------|
| 1. | Check Valve |
| 2. | Filter |
| 3. | Inlet pressure gauge |
| 4. | Outlet pressure gauge |
| 5. | Reducing valve M1 |
| 6. | Safety valve |
| 7. | Tank |

Don't assembly this way

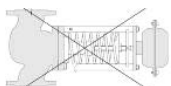

Disclaimer

The information, specifications and technical data contained in this catalogue are subject to change without notice by the manufacturer. The user should verify all technical data and specifications prior to use. EFSVALVES does not warrant that the material and information contained herein is current or correct and assumes no responsibility for the use or misuse of any such material and information by the users.